

# Model MS2100L - CorrTran AQUA

## LPR 4-20mA/HART® Transmitter

**Metal Samples' CorrTran AQUA** is a compact corrosion transmitter used in the water treatment industry that measures general corrosion, localized corrosion (pitting), and conductance, and transmits that information to operators via 4 to 20mA / HART® protocol in real time. The corrosion rate or pitting factor is configured as the primary variable using a standard 2-wire 4 to 20 mA output. The remaining outputs are configured as secondary and tertiary HART variables.

The CorrTran AQUA utilizes state-of-the-art algorithms and data analysis techniques to accurately measure general corrosion rate and pitting. Harmonic distortion analysis (HDA) is applied to improve the performance of the industry-accepted linear polarization resistance (LPR) technique used to measure corrosion rate.

To further enhance the performance, an application-specific Stern-Geary variable (B value) is calculated and updated every measuring cycle. There is no need to manually update the B value because of process changes. During the measurement cycle, the CorrTran AQUA also performs an automated electrochemical noise (ECN) measurement, which in combination with the corrosion rate data can provide a measurement of localized corrosion (pitting).

The CorrTran AQUA works with Metal Samples three-electrode CorrTran style probes and electrodes. Probes are available in a variety of mounting types and materials to suit almost any type of installation.



*Probe shown in photo not included with transmitter*

### Features

- On-line corrosion monitoring, multivariable
- Install in an existing coupon rack
- 2-wire, 4 to 20 mA transmitter, HART interface
- General corrosion, localized corrosion (pitting), and conductance monitoring via HART
- Stern-Geary B value automatically updated for changes in the process
- Optional local LCD

## Ordering Information

Transmitter Model		
MS21	CorrTran AQUA Transmitter	
	<b>Display</b>	
	0	No Display
	5	With Display
	<b>Cable Entry</b>	
	0L	4-Pin Electrical Connector (External)
	1L	Cable Gland Entry (Internal 3-Pin Electrical Connector)
MS21	0	0L

Accessories	
ET915549	CorrTran Com Tools
ET915548	HART modem, HART to USB interface
ET1804	HART Loop Converter. Converts HART signal to 3 separate 4 to 20 mA outputs.

## Technical Specifications

<b>Model</b>	MS2100L CorrTran AQUA LPR 4-20mA/HART Transmitter
<b>Physical Data</b>	
Instrument Weight	1.1 lb (500 g)
Instrument Dimensions	7.1" x 5.4" x 2.4" (180mm x 137mm x 61mm) without LCD display 7.1" x 5.4" x 3.4" (180mm x 137mm x 86mm) with LCD display
Operating Temperature	-40 to 158°F (-40 to 70°C) without LCD display 14 to 122°F (-10 to 50°C) with LCD display
Enclosure Material	ABS
Degree of Protection	IP66, NEMA 4X

<b>Electrical Data</b>	
Electrical Connection	2-wire 4-20 mA with HART
Supply Voltage	11-30 VDC without LCD display 15-30 VDC with LCD display
Current Consumption	4 to 22.5 mA
Maximum Load (at 24 V DC)	575 Ω with high alarm / 650 Ω without high alarm (without display) / 850 Ω without high alarm (with display)

<b>Measurement Data</b>			
Probe Type	3-Electrode LPR		
Measurement Type	<b>General Corrosion<sup>1</sup></b>	<b>Localized Corrosion</b>	<b>Conductance</b>
Measurement Unit	mpy (mils per year) or mmpy (mm per year)	Unitless	microSiemens (μS)
Measurement Range(s)	Default Range: 0 to 40 mpy (0 to 1 mmpy)	Low Range: 0.0 to 0.01	5 to 333,333
Measurement Range(s)	Maximum <sup>2</sup> : 1000 mpy (25 mmpy)	Medium Range: 0.01 to 0.1	
	<sup>1</sup> Instantaneous corrosion rate available as a primary variable. Average corrosion rate available via HART. <sup>2</sup> Range adjustable via HART or factory set. Adjustment for these variables can be achieved through any HART-compatible device using the CorrTran MV DD or with PACTware: configuration software that makes it easy to program equipment via HART.	High Range: 0.1 to 1.0	
Factory Settings	B value (Stern Geary value): 25.6 mV K value (corrosion constant): 11800 (2e- in reaction)		
Measurement Cycle	4 to 34 minutes (depends on configuration)		

<b>Output Data</b>	
Output Signal	4-20 mA with HART protocol
Alarm Events	Alarm on over-range
Alarm Types	Digital and Analog (configurable)
Analog Alarm Options	Current high (22.5 mA) with auto-reset (default), current high with manual reset, or none
Load	Minimum load for HART communication: 250 Ω

<b>Certificates and Approvals</b>	
Patents	U.S. patents: 7,239,156; 7,245,132; 7,265,559; 7,282,928

<b>Conformity Information</b>	
Degree of Protection	EN 60529

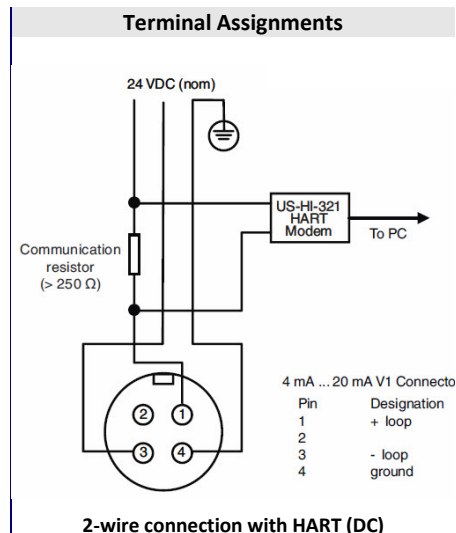

### Metal Samples Company

A Division of Alabama Specialty Products, Inc.

152 Metal Samples Rd., Munford, AL 36268 Phone: (256) 358-4202 Fax: (256) 358-4515

E-mail: [msc@alspi.com](mailto:msc@alspi.com) Internet: [www.metalsamples.com](http://www.metalsamples.com)

Houston Office: 6327 Teal Mist Lane, Fulshear, TX 77441 Phone: (832) 451-6825